

3.0	EXISTING SETTING	3-1
3.1	Introduction	3-1
3.2	Air Quality	3-1
3.2.1	Regional Climate	3-2
3.2.2	Meteorology in the Vicinity of the Project	3-4
3.2.3	Existing Air Quality	3-9
3.2.4	Regional Emissions Inventory.....	3-15
3.2.5	Regulatory Setting	3-19
3.3	Geology and Soils	3-19
3.3.1	Geologic Setting	3-19
3.3.2	Structural Setting	3-19
3.3.3	Seismicity	3-20
3.3.4	Soils (Surficial Geology)	3-21
3.4	Hazards and Hazardous Materials	3-23
3.5	Hydrology and Water Quality.....	3-25
3.5.1	Surface Water Quality.....	3-25
3.5.2	Groundwater Quality.....	3-31
3.6	Noise.....	3-31
3.6.1	Regulations	3-32
3.6.2	Existing Noise Environment.....	3-34
3.7	Transportation/Traffic	3-34
3.7.1	Surrounding Highway and Rail Network.....	3-35
3.7.2	Local Roadways and Circulation Routes.....	3-35
3.8	Other Issue Areas Eliminated During the Initial Study	3-36

LIST OF FIGURES

Figure 3.2-1	Meteorological Monitoring Stations in the Project Area.....	3-6
Figure 3.2-2	Windrose – Burbank Monitoring Station (1981)	3-7
Figure 3.2-3	Dominant Wind Patterns in the Basin	3-8
Figure 3.2-4	Major Pollutants Contributing To Cancer Risk In The South Coast Air Basin....	3-15
Figure 3.5-1	Valley Generating Station Schematic of Process Water Flow.....	3-29

LIST OF TABLES

Table 3.2-1	Average Monthly Temperatures and Precipitation for Los Angeles International Airport, CA, 1961-1990	3-5
Table 3.2-2	Ambient Air Quality Standards.....	3-10
Table 3.2-3	Background Air Quality Data for the East San Fernando Valley Station (ID No. 069) - (1996 - 1999).....	3-12
Table 3.2-4	Sources of Criteria Pollutant Emissions Caused by Human Activities for Baseline Year 1993 (ton/day, annual average).....	3-16

Table 3.2-5 Annual Facility Emissions for VGS 3-17

Table 3.2-6 1998 Annual Average Day Toxic Emissions for the South Coast Air Basin
(lbs/day) 3-18

Table 3.3-1 Ground Motion and Maximum Magnitude Estimates for the Project Site..... 3-20

Table 3.4-1 Emergency Response Planning Guidelines (Ammonia Impact) 3-25

Table 3.5-1 Valley Generating Station’s Discharge Limitations..... 3-30

Table 3.6-1 City of Los Angeles Noise Ordinances 3-34

Table 3.7-1 Intersection Capacity Utilization (ICU) Summary – Existing Conditions 3-36

3.0 EXISTING SETTING

3.1 Introduction

In order to determine the significance of the impacts associated with a proposed project, it is necessary to evaluate the project's impacts against the backdrop of the environment as it exists at the time the NOP/IS is published. The CEQA Guidelines define "environment" as "the physical conditions that exist within the area which will be affected by a proposed project including land, air, water, minerals, flora, fauna, ambient noise, and objects of historical or aesthetic significance" (CEQA Guidelines §15360; see also Public Resources Code §21060.5). Furthermore, a CEQA document must include a description of the physical environment in the vicinity of the project, as it exists at the time the NOP is published, from both a local and regional perspective (CEQA Guidelines §15125). Therefore, the "environment" or "existing setting" against which a project's impacts are compared consists of the immediate, contemporaneous physical conditions at and around the project site (Remy et al., 1996).

This chapter presents the existing setting for each environmental topic analyzed in this report. This [Draft/Final](#) EIR is focused only on the environmental topics identified in the IS as having the potential for being adversely affected by this project, i.e., air quality, geology/soils, hazards and hazardous materials, hydrology/water quality, noise, and transportation/traffic. The reader is referred to the IS (Appendix A) for a discussion of environmental topics not considered in this [Draft/Final](#) EIR and the rationale for inclusion or exclusion of each environmental topic. In Chapter 4, potential significant adverse impacts from these identified environmental areas are then compared to the existing setting to determine whether the effects of the implementation of the proposed project are significant.

3.2 Air Quality

The SCAQMD has jurisdiction over an area of approximately 10,743 square miles, consisting of the four-county South Coast Air Basin (Basin) (Orange County and the non-desert portions of Los Angeles, Riverside and San Bernardino counties), and the Riverside County portions of the Salton Sea Air Basin (SSAB) and Mojave Desert Air Basin (MDAB). The Basin, which is a subarea of the SCAQMD's jurisdiction, is bounded by the Pacific Ocean to the west and the San Gabriel, San Bernardino, and San Jacinto mountains to the north and east. It includes all of Orange County and the non-desert portions of Los Angeles, Riverside, and San Bernardino counties. The Los Angeles County portion of MDAB (known as north county or Antelope Valley) is bounded by the San Gabriel Mountains to the south and west, the Los Angeles/Kern county border to the north, and the Los Angeles/San Bernardino county border to the east. The Riverside County portion of the SSAB is bounded by the San Jacinto Mountains in the west and spans eastward up to the Palo Verde Valley. The federal nonattainment area (known as the Coachella Valley Planning Area) is a subregion of the Riverside County and the SSAB that is bounded by the San Jacinto

Mountains to the west and the eastern boundary of the Coachella Valley to the east (Figure 1.1-1).

VGS lies within the Basin (Figure 1.1-1). The current air quality setting in the vicinity of the VGS are discussed in the following sections. Portions of this discussion are taken from Keith (1980).

3.2.1 Regional Climate

The regional climate significantly influences the air quality in the Basin. Temperature, wind, humidity, precipitation and even the amount of sunshine influence the quality of the air. In addition, the Basin is frequently subjected to an inversion layer that traps air pollutants. Temperature has an important influence on Basin wind flow, pollutant dispersion, vertical mixing, and photochemistry.

Annual average temperatures throughout the Basin vary from the low to middle 60° Fahrenheit (F). However, due to decreased marine influence, the eastern portion of the Basin shows greater variability in average annual minimum and maximum temperatures. January is the coldest month throughout the Basin, with average minimum temperatures of 47° F in downtown Los Angeles and 36° F in San Bernardino. All portions of the Basin have recorded maximum temperatures above 100° F.

Although the climate of the Basin can be characterized as semi-arid, the air near the land surface is quite moist on most days because of the presence of a marine layer. This shallow layer of sea air is an important modifier of Basin climate. Humidity restricts visibility in the Basin, and the conversion of sulfur dioxide to sulfates is heightened in air with high relative humidity. The marine layer is an excellent environment for that conversion process, especially during the spring and summer months. The annual average relative humidity is 71 percent along the coast, and 59 percent inland. Because the ocean effect is dominant, periods of heavy early morning fog are frequent, and low stratus clouds are a characteristic feature. These effects decrease with distance from the coast.

More than 90 percent of the Basin's rainfall occurs from November through April. Annual average rainfall varies from approximately nine inches in Riverside to 14 inches in downtown Los Angeles. Monthly and yearly rainfall totals are extremely variable. Summer rainfall usually consists of widely scattered thundershowers near the coast and slightly heavier shower activity in the eastern portion of the region and near the mountains. Rainy days comprise five to 10 percent of all days in the Basin with the frequency being higher near the coast. The influence of rainfall on the contaminant levels in the Basin is minimal. Although some wash-out of pollution would be expected with winter rains, air masses that bring precipitation of consequence are very unstable and provide excellent dispersion that masks wash-out effects. Summer thunderstorm activity affects pollution only to a limited degree. If the inversion is not broken by a major weather system, high contaminant levels can persist even in areas of light showers. However, heavy clouds

associated with summer storms minimize ozone production because of reduced sunshine and cooler temperatures.

Due to the generally clear weather, about three-quarters of available sunshine is received in the Basin. The remaining one-quarter is absorbed by clouds. The ultraviolet portion of this abundant radiation is a key factor in photochemical reactions. On the shortest day of the year there are approximately 10 hours of possible sunshine, and approximately 14½ hours on the longest day of the year. The percentage of cloud cover during daylight hours varies from 47 percent at Los Angeles International Airport (LAX) to 35 percent at Sanberg, a mountain location. The number of clear days also increases with distance from the coast; 145 days at LAX and 186 days at Burbank (Local Climatological Data, 1999). The Basin typically receives much less sunshine during the first six months of the year than the last six months. This difference is attributed to the greater frequency of deep marine layers and the subsequent increase in stratus clouds during the spring and to the fact that the rainy season begins late in the year (November) and continues through early spring.

The importance of wind to air pollution is considerable. The direction and speed of the wind determines the horizontal dispersion and transport of air pollutants. During the late autumn to early spring rainy season, the Basin is subjected to wind flows associated with traveling storms moving through the region from the northwest. This period also brings five to 10 periods of strong, dry offshore winds, locally termed “Santa Anas” each year. During the dry season, which coincides with the months of maximum photochemical smog concentrations, the wind flow is bimodal, typified by a daytime onshore sea breeze and a nighttime offshore drainage wind. Summer wind flows are created by the pressure differences between the relatively cold ocean and the unevenly heated and cooled land surfaces that modify the general northwesterly wind circulation over southern California. Nighttime drainage begins with the radiational cooling of the mountain slopes. Heavy, cool air descends the slopes and flows through the mountain passes and canyons as it follows the lowering terrain toward the ocean. Another characteristic wind regime in the Basin is the “Catalina Eddy,” a low level cyclonic (counterclockwise) flow centered over Santa Catalina Island which results in an offshore flow to the southwest. On most spring and summer days, some indication of an eddy is apparent in coastal sections.

The vertical dispersion of air pollutants in the Basin is frequently restricted by the presence of a persistent temperature inversion in the atmospheric layers near the earth’s surface. Normally, the temperature of the atmosphere decreases with altitude. However, when the temperature of the atmosphere increases with altitude, the phenomenon is termed an inversion. An inversion condition can exist at the surface or at any height above the ground. The bottom of the inversion, known as the mixing height, is the height of the base of the inversion.

In the Basin, there are two distinct temperature inversion structures that control vertical mixing of air pollution. During the summer, warm, high-pressure descending (subsiding) air is undercut by a shallow layer of cool marine air. The boundary between these two layers of air is a persistent

marine subsidence/inversion. This boundary prevents vertical mixing which effectively acts as an impervious lid to pollutants over the entire Basin. The mixing height for this inversion structure is normally situated 1,000 to 1,500 feet above mean sea level.

A second inversion-type forms in conjunction with the drainage of cool air off the surrounding mountains at night followed by the seaward drift of this pool of cool air. The top of this layer forms a sharp boundary with the warmer air aloft and creates nocturnal radiation inversions. These inversions occur primarily in the winter, when nights are longer and onshore flow is weakest. They are typically only a few hundred feet above mean sea level. These inversions effectively trap pollutants, such as NO_x and CO from vehicles, as the pool of cool air drifts seaward. Winter is therefore a period of high levels of primary pollutants along the coastline.

In general, inversions in the Basin are lower before sunrise than during the daylight hours. As the day progresses, the mixing height normally increases as the warming of the ground heats the surface air layer. As this heating continues, the temperature of the surface layer approaches the temperature of the base of the inversion layer. When these temperatures become equal, the inversion layer's lower edge begins to erode, and if enough warming occurs, the layer breaks up. The surface layers are gradually mixed upward, diluting the previously trapped pollutants. The breakup of inversion layers frequently occurs during mid- to late-afternoon on hot summer days. Winter inversions usually break up by mid-morning.

3.2.2 Meteorology in the Vicinity of the Project

The coastal area is dominated by a semi-permanent, subtropical, Pacific high-pressure system. Generally mild, the climate is tempered by cool sea breezes, but may be infrequently interrupted by periods of extremely hot weather, passing winter storms, or Santa Ana winds. VGS is located somewhat further inland where the temperature is generally higher and the relative humidity lower than along the coast.

Summers in the area are warmer than along the immediate coast, with peak temperatures averaging near 80° F. Rainfall averages about 14.5 inches a year, falling almost entirely from late October to early April. The meteorological data (temperature and precipitation) from LAX are detailed in Table 3.2-1.

**Table 3.2-1
Average Monthly Temperatures and Precipitation for
Los Angeles International Airport, CA, 1961-1990**

Month	Los Angeles International Airport		
	Mean Daily Temperatures		Mean Monthly Precipitation (inches)
	Maximum (°F)	Minimum (°F)	
January	65	47	2.40
February	66	49	2.51
March	65	50	1.98
April	68	53	0.72
May	69	56	0.14
June	72	60	0.03
July	75	63	0.01
August	76	64	0.15
September	76	63	0.31
October	74	59	0.34
November	71	52	1.76
December	66	48	1.66
Absolute extreme temperatures	110	23	12.01 (total)
Reference: 1999 Local Climatological Data, Annual Summary with Comparative Data, Los Angeles, California, International Airport			

The East San Fernando Valley monitoring station (site 069) is the most representative of the ambient air quality in the vicinity of VGS. The location of East San Fernando Valley monitoring station is shown in Figure 3.2-1. Air quality dispersion modeling performed for the proposed project will utilize 1981 wind data from the Burbank monitoring station (not shown), in accordance with SCAQMD convention. An annual wind rose for Burbank monitoring station is shown in Figure 3.2-2. Typical winter and summer season wind patterns for morning and afternoon for the Basin are shown in Figure 3.2-3.

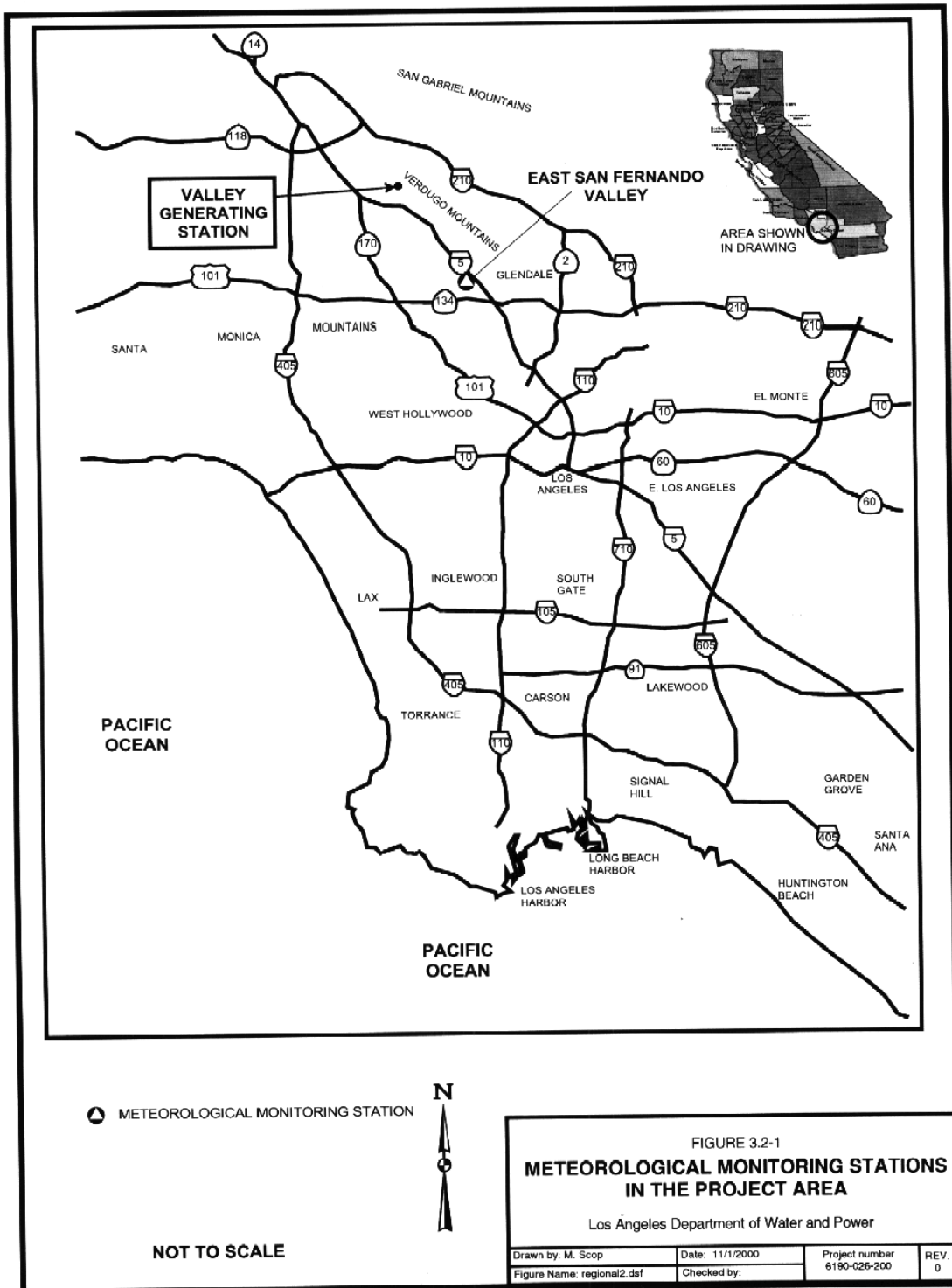

Figure 3.2-1 Meteorological Monitoring Stations in the Project Area

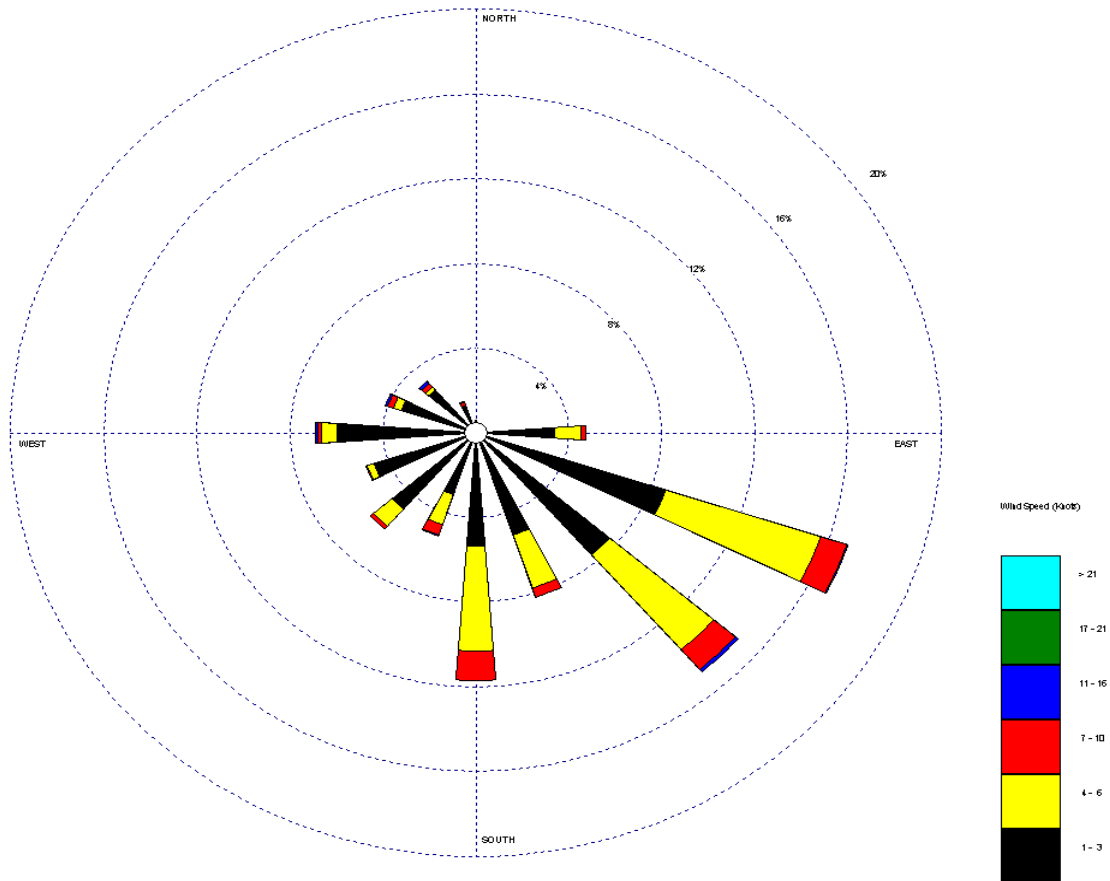

Figure 3.2-2 Windrose – Burbank Monitoring Station (1981)
[Note: Wind direction is the direction the wind is blowing from]

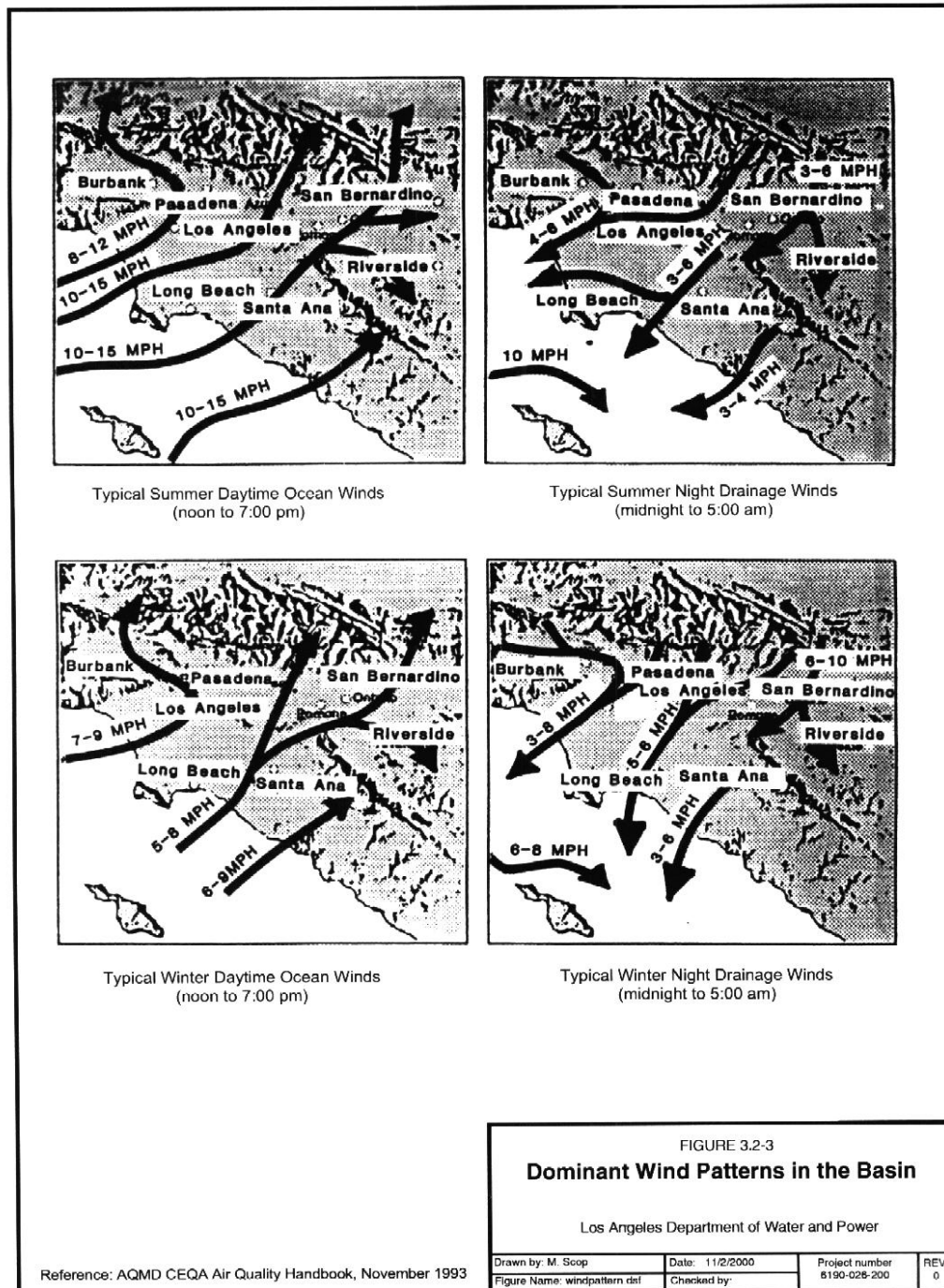

Figure 3.2-3 Dominant Wind Patterns in the Basin

3.2.3 Existing Air Quality

Air quality is determined primarily by the type and amount of contaminants emitted into the atmosphere, the size and topography of the air basin, and the meteorological conditions. The Basin has low mixing heights and light winds, which are conducive to the accumulation of air pollutants. Pollutants that impact air quality are generally divided into two categories: criteria pollutants (those for which health standards have been set) and toxic air contaminants (those that cause cancer or have adverse human health effects other than cancer).

3.2.3.1 Criteria Pollutants

The determination of whether a region's air quality is healthful or unhealthful is determined by comparing contaminant levels in ambient air samples to national and state standards. These standards are set by the U.S. EPA and the California Air Resources Board (CARB) at levels to protect public health and welfare with an adequate margin of safety. National Ambient Air Quality Standards (NAAQS) were first authorized by the federal Clean Air Act of 1970. California Ambient Air Quality Standards (CAAQS) were authorized by the state legislature in 1967. Air quality of a region is considered to be in attainment of the standards if the measured ambient air pollutant levels for ozone, CO, SO₂ (1- and 24-hour), NO₂, PM₁₀, are not exceeded, and all other standards are not equaled or exceeded at any time in any consecutive three-year period. National standards (other than ozone, PM₁₀, and those based on annual averages or arithmetic mean) are not to be exceeded more than once per year. The ozone standard is attained when the fourth highest eight-hour concentration in a year, averaged over three years, is equal to or less than the standard. For PM₁₀, the 24-hour standard is attained when 99 percent of the daily concentrations, averaged over three years, are equal to or less than the standard. The Basin is a non-attainment area for ozone, PM₁₀, and CO.

It is the responsibility of the SCAQMD to ensure that state and federal ambient air quality standards are achieved and maintained in the Basin. Health-based air quality standards have been established by California and the federal government for the following criteria air pollutants: ozone, CO, NO₂, PM₁₀, SO₂, and lead. These standards were established to protect sensitive receptors from adverse health impacts due to exposure to air pollution. The CAAQS are more stringent than the federal standards, and in the case of PM₁₀ and SO₂, much more stringent. California has also established standards for sulfate, visibility, hydrogen sulfide, and vinyl chloride. Hydrogen sulfide and vinyl chloride are currently not monitored in the Basin because these contaminants are not seen as a significant air quality problem. CAAQS and NAAQS for each of these pollutants and their effects on health are summarized in Table 3.2-2.

**Table 3.2-2
Ambient Air Quality Standards**

Air Pollutant	State Standard	Federal Primary Standard	Most Relevant Effects
	Concentration/ Averaging Time	Concentration/ Averaging Time	
Ozone	0.09 ppm, 1-hr. avg.	0.12 ppm, 1-hr avg., 0.08 ppm, 8-hr avg.	(a) Short-term exposures: (1) Pulmonary function decrements and localized lung edema in humans and animals (2) Risk to public health implied by alterations in pulmonary morphology and host defense in animals; (b) Long-term exposures: Risk to public health implied by altered connective tissue metabolism and altered pulmonary morphology in animals after long-term exposures and pulmonary function decrements in chronically exposed humans; (c) Vegetation damage; (d) Property damage
Carbon Monoxide	9.0 ppm, 8-hr avg. 20 ppm, 1-hr avg.	9 ppm, 8-hr avg. 35 ppm, 1-hr avg.	(a) Aggravation of angina pectoris and other aspects of coronary heart disease; (b) Decreased exercise tolerance in persons with peripheral vascular disease and lung disease; (c) Impairment of central nervous system functions; (d) Possible increased risk to fetuses
Nitrogen Dioxide	0.25 ppm, 1-hr avg.	0.053 ppm, annual arithmetic mean	(a) Potential to aggravate chronic respiratory disease and respiratory symptoms in sensitive groups; (b) Risk to public health implied by pulmonary and extra-pulmonary biochemical and cellular changes and pulmonary structural changes; (c) Contribution to atmospheric discoloration
Sulfur Dioxide	0.04 ppm, 24-hr avg. 0.25 ppm, 1-hr. avg.	0.030 ppm, annual arithmetic mean 0.14 ppm, 24-hr avg.	(a) Bronchoconstriction accompanied by symptoms which may include wheezing, shortness of breath and chest tightness, during exercise or physical activity in persons with asthma

**Table 3.2-2 (Concluded)
Ambient Air Quality Standards**

Air Pollutant	State Standard	Federal Primary Standard	Most Relevant Effects
	Concentration/ Averaging Time	Concentration/ Averaging Time	
Suspended Particulate Matter (PM10)	30 µg/m ³ , annual geometric mean 50 µg/m ³ , 24-hr avg.	50 µg/m ³ , annual arithmetic mean 150 µg/m ³ , 24-hr avg.	(a) Excess deaths from short-term exposures and exacerbation of symptoms in sensitive patients with respiratory disease; (b) Excess seasonal declines in pulmonary function, especially in children
Sulfates	25 µg/m ³ , 24-hr avg.	None	(a) Decrease in ventilatory function; (b) Aggravation of asthmatic symptoms; (c) Aggravation of cardiopulmonary disease; (d) Vegetation damage; (e) Degradation of visibility; (f) Property damage
Lead	1.5 µg/m ³ , 30-day avg.	1.5 µg/m ³ , calendar quarter	(a) Increased body burden; (b) Impairment of blood formation and nerve conduction
Visibility-Reducing Particles	In sufficient amount to reduce the visual range to less than 10 miles at relative humidity less than 70%, 8-hour average (10 am – 6 pm)	None	Visibility impairment on days when relative humidity is less than 70 percent
µg/m ³ = microgram per meter cubed ppm = parts per million			

The SCAQMD monitors levels of various criteria pollutants at 33 monitoring stations. Of the 33 monitoring stations, the East San Fernando Valley monitoring station (site 069) is the most representative of the ambient air quality in the vicinity of VGS. The location of East San Fernando Valley monitoring station is shown in Figure 3.2-1. Background ambient air quality data from the East San Fernando Valley monitoring station from 1996 through 1999 for criteria pollutants are presented in Table 3.2-3. Ambient air quality was compared to the most stringent of either the CAAQS or NAAQS. In all cases, CAAQS were the most stringent. These data indicate that the region surrounding VGS, as represented by the East San Fernando Valley monitoring station, is in compliance with both CAAQS and NAAQS for CO, NO₂, and SO₂.

State ozone and PM10 air quality standards were exceeded at the East San Fernando Valley monitoring station on several days each year. The number of days that the state ozone standard was exceeded varied from a low of 13 days in 1999 to a high of 34 days in 1998 over this period. Peak 24-hour PM10 concentration has decreased from 110 $\mu\text{g}/\text{m}^3$ to 82 $\mu\text{g}/\text{m}^3$ at this site. The number of observed exceedances of the state 24-hour PM10 standard have varied from a low of nine days in 1998 to a high of 21 days in 1999.

The state eight-hour CO standard was exceeded during this four-year period only once, in 1996. The maximum measured concentrations of NO₂ each year were less than the 0.25 ppm one-hour state standard and the national annual standard. The SO₂ concentrations were below state and national standards during this period. No data were available at this site for lead or sulfates from 1996 to 1999.

Table 3.2-3
Background Air Quality Data for the East San Fernando Valley Station
(ID No. 069) - (1996 - 1999)

Constituent	Maximum Observed Concentration (in ppm, unless otherwise noted) (No. of Standard Exceedances - most restrictive)					
	State Standard	Federal Standard	1996	1997	1998	1999
<u>Carbon monoxide</u>						
1-hour	20.0 ppm	35.0 ppm	12 (0 days)	9 (0 days)	8 (0 days)	9 (0 days)
8-hour	9.0 ppm	9.5 ppm	9.3 (1 day)	7.4 (0 days)	7.5 (0 days)	9.0 (0 days)
<u>Ozone</u>						
1-hour	0.09 ppm	0.12 ppm	0.14 (31)	0.13 (15 days)	0.18 (34 days)	0.12 (13 days)
<u>Nitrogen dioxide</u>						
1-hour	0.25 ppm	---	0.20 (0 days)	0.20 (0 days)	0.14 (0 days)	0.18 (0 days)
Annual	---	0.053 ppm	0.0461	0.0424	0.0416	0.0456
<u>Sulfur dioxide</u>						
1-hour	0.25 ppm	---	0.01 (0 days)	0.04 (0 days) ^a	0.01 (0 days)	0.01 (0 days)
24-hour	0.04 ppm	0.14 ppm	0.009 (0 days)	0.008(0 days) ^a	0.009 (0 days)	0.003 (0 days)
Annual	---	0.03 ppm	0.0004	0.0003 ^a	0.0002	0.0001
<u>PM10</u>						
24-hour	50 $\mu\text{g}/\text{m}^3$	150 $\mu\text{g}/\text{m}^3$	110 $\mu\text{g}/\text{m}^3$ (15 days)	92 $\mu\text{g}/\text{m}^3$ ^a (17 days) ^a	75 $\mu\text{g}/\text{m}^3$ (9 days)	82 $\mu\text{g}/\text{m}^3$ (21 days)
Annual Mean:						
Geometric	30 $\mu\text{g}/\text{m}^3$	---	37.5 $\mu\text{g}/\text{m}^3$	41.9 $\mu\text{g}/\text{m}^3$ ^a	32.8 $\mu\text{g}/\text{m}^3$	40.6 $\mu\text{g}/\text{m}^3$
Arithmetic	---	50 $\mu\text{g}/\text{m}^3$	41.5 $\mu\text{g}/\text{m}^3$	44.8 $\mu\text{g}/\text{m}^3$ ^a	36.0 $\mu\text{g}/\text{m}^3$	43.7 $\mu\text{g}/\text{m}^3$

Table 3.2-3 (Concluded)
Background Air Quality Data for the East San Fernando Valley Station
(ID No. 069) - (1996 - 1999)

Constituent	Maximum Observed Concentration (in ppm, unless otherwise noted) (No. of Standard Exceedances - most restrictive)					
	State Standard	Federal Standard	1996	1997	1998	1999
<u>Lead</u> 30-day	1.5 µg/m ³	---	No Data	No Data	No Data	No Data
Calendar Quarter	---	1.5 µg/m ³				
<u>Sulfates</u> 24-hours	25 µg/m ³	---	No Data	No Data	No Data	No Data

a = Incomplete record of data; may not be representative. PM10 and sulfate only monitored every 6 days.
 Reference: California Air Resources Board (CARB) Air Quality Data Annual Summaries 1995-1998; SCAQMD Air

3.2.3.2 Toxic Air Contaminants

Cancer Risk

One of the primary health risks of concern due to exposure to TACs is the risk of contracting cancer. The carcinogenic potential of TACs is a particular public health concern because it is currently believed by many scientists that there is no “safe” level of exposure to carcinogens, that is, any exposure to a carcinogen poses some risk of causing cancer. Health statistics show that one in four people will contract cancer over their lifetime, or 250,000 in a million, from all causes, including diet, genetic factors and lifestyle choices. Approximately two percent of cancer deaths in the United States may be attributable to environmental pollution (Doll and Peto, 1981).

Noncancer Health Risks

Unlike carcinogens, for most noncarcinogens it is believed that there is a threshold level of exposure to the compound below which it will not pose a health risk. The California Environmental Protection Agency and California Office of Environmental Health Hazard Assessment (OEHHA) have developed reference exposure levels (REL) for noncarcinogenic TACs that are health-conservative estimates of the levels of exposure at or below which health effects are not expected. The noncancer health risk due to exposure to a TAC is assessed by comparing the estimated level of exposure to the REL. The comparison is expressed as the ratio of the estimated exposure level to the REL, called the hazard index.

Multiple Air Toxics Exposure Study II (MATES II) Study

The MATES II study, which is the most comprehensive study of urban toxic air pollution ever undertaken, shows that motor vehicles and other mobile sources of air pollution are the predominant source of cancer-causing air pollutants in the Basin. The SCAQMD's Governing Board directed staff to undertake the MATES II study as part of the agency's environmental justice initiatives (e.g., EJ Initiative #7) adopted in late 1997. A panel of scientists from universities, an environmental group, businesses and other government agencies helped design and guide the study. The study was aimed at determining the cancer risk from toxic air pollution throughout the area by monitoring toxics continually for one year at 10 monitoring sites. Another goal was to determine if there were any sites where TAC concentrations emitted by local industrial facilities were causing a disproportionate cancer burden on surrounding communities. To address this second goal, the SCAQMD monitored toxic pollutants at 14 sites for one month each with three mobile monitors. Monitoring platforms were placed in or near residential areas adjacent to clusters of facilities. Although no TAC hotspots were identified, models show that elevated levels can occur very close to facilities emitting TACs.

In the MATES II study, SCAQMD monitored more than 30 TACs at 24 sites over a one-year period in 1999. The SCAQMD collected more than 4,500 air samples and together with the CARB performed more than 45,000 separate laboratory analyses of these samples. In the study, SCAQMD calculated cancer risk assuming 70 years of continuous exposure to monitored levels of pollutants.

The MATES II study found that the average carcinogenic risk throughout the Basin is approximately 1,400 in one million ($1,400 \times 10^{-6}$). Mobile sources (e.g., cars, trucks, trains, ships, aircraft, etc.) represent the greatest contributors. As shown in Figure 3.2-4, approximately 80 percent of all risk is attributed to diesel particulate emissions; approximately 20 percent to other toxics associated with mobile sources (including benzene, butadiene, and formaldehyde); and approximately 10 percent of all risk is attributed to stationary sources (which include industries and other certain businesses such as dry cleaners and chrome plating operations.)

Source: MATES II Final Report, March 2000, Page ES-9

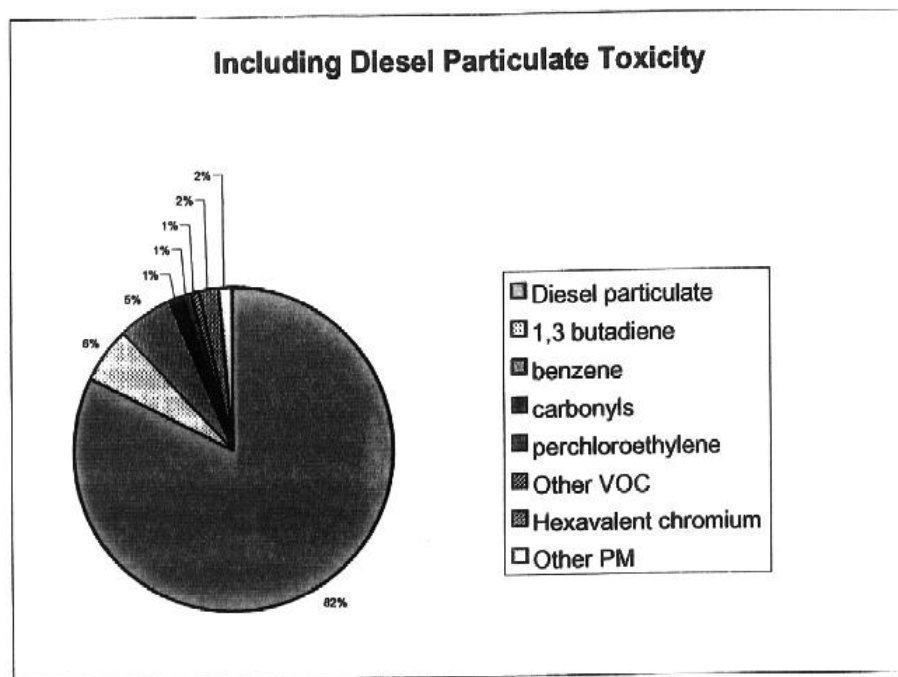

Figure 3.2-4 Major Pollutants Contributing To Cancer Risk In The South Coast Air Basin

3.2.4 Regional Emissions Inventory

SCAQMD has compiled emissions inventories for both criteria pollutants and TACs. The inventories are presented in the following subsections.

3.2.4.1 Criteria Pollutants Inventory

SCAQMD's current emissions inventory for the Basin is summarized in Table 3.2-4. The emissions inventory for the anthropogenic inventory is made up of stationary sources (both point and area sources are in this category) and mobile sources encompassing on-road and off-road mobile sources. On-road mobile sources include light-duty passenger vehicles; light-, medium-, and heavy-duty trucks; motorcycles, and urban buses. Off-road mobile sources include off-road vehicles, trains, ships, aircraft, and mobile equipment. The SCAQMD emissions inventory only includes emissions in the Basin of the criteria air pollutants NO_x , CO, SO_x , PM₁₀, and VOC (a precursor of criteria air pollutants). Since ozone is formed by photochemical reactions involving the precursors VOC and NO_x , it is not inventoried.

Table 3.2-4
Sources of Criteria Pollutant Emissions Caused by Human Activities
for Baseline Year 1993
(ton/day, annual average)

Source Category	NO_x	SO_x	CO	VOC	PM10
Stationary and area sources	155.49	23.12	98.90	461.73	387.32
Mobile sources (on- and off-road)	1,134.32	75.42	8,562.40	857.27	45.36
Total	1,289.81	98.54	8,661.30	1,319.00	432.68
Source: Appendix III, 1997 AQMP					

As shown in Table 3.2-4, mobile sources are the major contributors to CO (99 percent), NO_x (88 percent), SO_x (77 percent), and VOC (65 percent) emissions in the Basin. Stationary and area sources are the major contributors to PM10 emissions (90 percent).

3.2.4.2 VGS Emission Inventory

VGS has been in operation for many years. There are four boilers at the facility; two are in intermittent operation, and two have not been operated since the early 1990s. The facility is permitted to operate on both fuel oil and natural gas, although the boilers have not been operated on fuel oil since the late 1980s. Other emission sources at the facility include fuel storage tanks, small internal combustion engines, and a paint spray booth. The boilers historically release in excess of 99 percent of the emissions from the facility.

In recent years, VGS has operated two boilers using natural gas exclusively as fuel. The emissions for the last two years of operation are presented in Table 3.2-5.

**Table 3.2-5
Annual Facility Emissions for VGS**

Pollutant	1999-00 Emissions Lbs/Yr	2000-01 Emissions Lbs/Yr	2-Yr Average	
			Lbs/Yr	Lbs/day ^a
NO _x	195,660	188,600	192,130	526.38
SO _x	1,655	2,294	2,802	7.68
VOC	17,604	24,414	21,011	57.56
CO	29,910	41,474	35,692	97.79
PM10	4,985	6,912	5,949	16.30

a = Average calculated assuming 365-day per year operation. This method is consistent with the method required in Rule 1306 for calculating emission decreases, however, does not accurately reflect peak daily emission rates.
Sources: 1999-00 Annual Emission Report and 2000-01 Annual Emission Report

3.2.4.3 Toxic Pollutants Inventory

The data available for toxic emissions inventories are not nearly as complete as the data for criteria pollutants. Starting in 1989, industrial facilities have been required to compile toxic emissions inventories under the AB 2588 program. Companies subject to the program are required to report their toxic emissions to the SCAQMD.

The SCAQMD's first toxic air pollutant emissions inventory was compiled for 30 TACs for the year 1982 for stationary sources only. This inventory was updated during the preparation of the 1999 MATES II study, which consisted of an evaluation and a characterization of ambient air toxics data in the District. The MATES II inventory is the most up-to-date inventory prepared by the SCAQMD. It also estimated the cancer risk of several TACs. For the study, 20 of the original 30 pollutants were updated for the year 1998. Additionally, mobile source emissions for 12 of the 20 toxic pollutants were compiled. The stationary source data included 1,244 point sources and the mobile source inventory included only on-road motor vehicles. A summary of the 1998 toxics emissions inventory is presented in Table 3.2-6, which provides the estimated toxic emissions for selected compounds, by source category.

**Table 3.2-6
1998 Annual Average Day Toxic Emissions for the South Coast Air Basin (lbs/day)**

Pollutant	On-Road	Off-Road	Point	AB2588	Area	Total
Acetaldehyde ^a	5485.8	5770.3	33.9	57.1	189.1	11536.2
Acetone	4945.8	4824.7	3543.5	531.4	23447.4	37292.8
Benzene	21945.5	6533.4	217.7	266.8	2495.4	31458.8
Butadiene [1,3]	4033.8	1566.1	6.7	2.0	151.3	5759.9
Carbon tetrachloride	0.0	0.0	8.8	1.8	0.0	10.6
Chloroform	0.0	0.0	0.0	35.5	0.0	35.5
Dichloroethane [1,1]	0.0	0.0	0.0	0.1	0.0	0.1
Dioxane [1,4]	0.0	0.0	0.0	105.0	0.0	105.0
Ethylene dibromide	0.0	0.0	0.0	0.2	0.0	0.2
Ethylene dichloride	0.0	0.0	4.9	17.6	0.0	22.5
Ethylene oxide	0.0	0.0	58.1	12.3	454.1	524.4
Formaldehyde ^a	16664.9	16499.3	521.6	674.7	1107.5	35468.0
Methyl Ethyl Ketone ^a	905.1	906.9	3240.2	385.9	14535.4	19973.5
Methylene chloride	0.0	0.0	1378.6	1673.6	9421.7	12473.9
Methyl tertiary butyl ether (MTBE)	58428.9	2679.2	40.5	434.4	5473.7	67056.7
p-Dichlorobenzene	0.0	0.0	0.0	4.5	3735.6	3740.1
Perchloroethylene	0.0	0.0	4622.0	2249.1	22813.1	29684.2
Propylene oxide	0.0	0.0	0.0	22.3	0.0	22.3
Styrene	1114.8	287.1	447.0	3836.7	21.4	5707.0
Toluene	63187.6	11085.9	5689.6	3682.4	52246.7	135892.2
Trichloroethylene	0.0	0.0	1.1	58.0	2550.3	2609.3
Vinyl chloride	0.0	0.0	0.0	4.3	0.0	4.3
Arsenic	0.1	0.3	2.7	0.7	21.4	25.2
Cadmium	1.6	1.5	0.5	0.7	27.5	31.8
Chromium	2.4	2.3	3.9	2.2	302.2	313.0
Diesel particulate	23906.3	22386.3	0.0	5.4	815.3	47113.4
Elemental carbon ^b	27572.1	6690.3	702.8	0.0	16770.5	51735.7
Hexavalent chromium	0.4	0.4	0.3	1.0	0.1	2.2
Lead	0.7	0.9	1.9	24.5	1016.3	1044.3
Nickel	2.5	2.2	2.9	21.6	85.6	114.9

Table 3.2-6 (Concluded)
1998 Annual Average Day Toxic Emissions for the South Coast Air Basin (lbs/day)

Pollutant	On-Road	Off-Road	Point	AB2588	Area	Total
Organic carbon	16426.2	15381.8	0.0	0.0	108612.1	140420.2
Selenium	0.1	0.1	3.0	5.7	2.6	11.6
Silicon	68.6	67.6	167.2	0.0	248614.0	248917.4

Source: Final MATES II Study, SCAQMD (March 2000).
a = Primarily emitted.
b = Including elemental carbon from all sources; including diesel particulate.

3.2.5 Regulatory Setting

The SCAQMD has regulatory jurisdiction over the air quality issues related to the proposed project. The project must comply with relevant SCAQMD rules and regulations in order to be issued permits to construct and operate. In addition, the project must comply with the relevant federal air quality requirements. The SCAQMD and federal air quality rules and regulations relevant to the proposed project are summarized in Table 2.5-1 in Chapter 2.

3.3 Geology and Soils

The installation of new combustion turbine generators and ancillary equipment including aqueous ammonia tanks at the VGS will require only moderate amounts of excavation and grading as part of the new construction. The following discussion describes elements of the existing geology and soils that may be affected by the proposed project.

3.3.1 Geologic Setting

The VGS is located on sandy soil and fill overlying alluvium along the northeast side of the San Fernando Valley. Geographically the site is located along the Tujunga Wash adjacent to the Verdugo Mountains. The San Fernando Valley is bounded to the north by the San Gabriel Mountains, to the east by the Verdugo Mountains, to the west by the Simi Hills and to the south by the Santa Monica Mountains. These features are located within the Transverse Ranges geological province of California. Groundwater is generally deeper than 50 feet below ground surface (bgs) and the LADWP reported in 1992 that groundwater in five wells in the area was between 180 and 200 feet bgs (Magula and Owen, 2000). The following discussion describes elements of the existing geology and soils that may be affected by the proposed project.

3.3.2 Structural Setting

The San Fernando Valley is an alluvial filled syncline that trends east west. The alluvium varies in thickness from zero at the edges to over 650 feet thick in the deepest portions of the valley (Dibblee, 1991). The alluvium is composed of gravel, sand, clay and silt sediments that were deposited by rivers and streams. The subsurface lithology includes inter-layered channel fill

deposits, overbank deposits, flood deposits and sheet flow deposits. The surrounding mountains are fault bounded as discussed in more detail under the seismicity section.

The area has been mined as a source of gravel. Currently there is an 80-foot deep excavation of a former gravel quarry located as shown on Figure 2.3-3.

3.3.3 Seismicity

The VGS is located in an area of well-known seismic activity. Historic seismic records indicate that between 1932 and 2000, approximately 37 earthquakes of Richter magnitude 5.0 or greater have occurred within 50 miles of the site (Magula and Owen, 2000). Approximately 35 active faults are also known to exist with a 50-mile radius of VGS. Of primary concern to the VGS are five faults located within 10 miles of VGS; the Verdugo Fault, the Oak Ridge Fault, the Sierra Madre-San Fernando Fault, the Northridge Hills Fault, and the Santa Monica Fault. As a result of their proximity, these geologic structures are considered to be the most likely sources for significant seismic effects at VGS (Magula and Owen, 2000). The Verdugo Fault is the closest identified active fault to the facility. The greatest concentration of historical, local seismic events has resulted from activity on the Oak Ridge Fault (primarily related to the 1994 Northridge earthquake) and activity on the Sierra Madre-San Fernando Fault (related to the 1971 San Fernando earthquake).

3.3.3.1 Important Historic Earthquakes/Earthquake Probability

The LADWP had a seismic hazard assessment completed on the VGS in November 2000 (Magula and Owen, 2000). The results of this study indicate that the VGS is subject to the effects of moderate to large seismic events. Based on this analysis, the Verdugo Fault was identified as the structure most likely to cause the earthquake that would result in peak ground accelerations.

The Verdugo Fault is a northeast dipping, reverse fault. Although the Dibblee 1991 map illustrates the buried trace of the fault as located approximately 400 feet to the northwest of the facility, the groundwater barrier reportedly marked by the fault is shown as approximately 1,900 feet west of the facility (Los Angeles Department of Water and Power, 1992). Magula and Owen, 2000, studied the discrepancy and determined that the location 1,900 feet to the west was the more appropriate location based on the subsurface evidence of a groundwater barrier. This fault is capable of generating an earthquake with a maximum moment magnitude of 6.7. A seismic hazard analysis was performed to determine the expected peak ground acceleration with a 10 percent probability of exceedance in 50 years.

Table 3.3-1 summarizes the calculated estimates for probable ground motion resulting from an earthquake at the VGS site. Details regarding the calculations are available in Magula and Owen, 2000.

**Table 3.3-1
Ground Motion and Maximum Magnitude Estimates for the Project Site**

Site	Ground Motion (ground acceleration) (10% probability of exceedance in 50 years)	Maximum Earthquake Magnitude (distance in kilometers)	Source
Valley Generating Station	0.9 g ^a	6.7 (less than 2 km)	Magula and Owen, 2000 Valley Generating Station Gas Turbine Project Geotechnical Report
a = The acceleration due to gravity or 32 feet/second ² km = kilometer			

3.3.3.2 Ground Rupture - Earthquake Zoning

The Alquist-Priolo Special Studies Zones Act specifies that an area, termed an “Earthquake Fault Zone” is to be delineated surrounding faults that are deemed “sufficiently active” or “well defined” after a review of seismic records and geological studies. This legislation was passed to prohibit the location of most structures for human occupancy across the traces of active faults and to mitigate thereby the hazard of earthquake-induced ground rupture. Cities and counties affected by zones must regulate certain existing and development projects within the zones by permitting and building code enforcement (California Division of Mines and Geology [CDMG], 1999).

Although located in an acknowledged seismically active area, the VGS is not located on a fault trace as designated by mapping and site investigations conducted as part of the Alquist-Priolo Earthquake Fault Zoning Act. The site specific study completed by Magula and Owen, 2000, concluded, “The hazard from fault rupture at the proposed site is considered slight.”

3.3.3.3 Subsidence

Based on the soil types present, the coarse sand and gravel present in the subsurface, the dense nature of subsurface materials, and the reported depth to groundwater, it is unlikely that seismic settlement or liquefaction would occur at the VGS. The potential for seismically induced landslides is discussed further in Section 3.3.4.3.

3.3.4 Soils (Surficial Geology)

Native soils in the VGS area are reportedly part of the Hanford Association. Hanford Association soils are well drained, coarse sandy loam underlain by gravelly loam (California SCS, 1969). The surface materials at the VGS have been disturbed by gravel mining and grading for placement of the existing structures. Two test pits were excavated to a depth of 50 feet on the site during the geotechnical investigation in 2000. The subsurface material present consisted of gravelly sand. The unified soil classification of the material after the gravel cobbles and boulders were screened out was poorly graded sand (SP) and silty sand (SM). One test pit revealed 2.5 feet of fill material at the surface that was composed of poorly graded sand with gravel, cobbles, boulders, wood, metal and pipes present (Magula and Owen, 2000).

3.3.4.1 Expansive Soils

Expansive soils have the ability to shrink and swell with wetting and drying. The shrink-swell capacity of expansive soils can result in differential movement beneath foundations. Investigation of the VGS site indicates that the majority of the near surface soils are granular in nature. Accordingly, the expansion potential of site soils is anticipated to be low.

3.3.4.2 Soil Liquefaction

Soil liquefaction is a phenomenon in which saturated, cohesionless soils (sand) temporarily lose their strength and liquefy when subjected to dynamic forces such as intense and prolonged ground shaking. Liquefaction typically occurs when the water table is less than 40 feet below ground surface and the soils are predominantly granular and unconsolidated. The potential for liquefaction increases as the groundwater approaches the surface. Recent analysis of seismic hazards in California by the CDMG indicate that the VGS site is not in an area where historic occurrence of liquefaction indicates a potential for permanent ground displacements (CDMG, 1999). Based on the soil types present, the coarse sand and gravel present in the subsurface, the dense nature of subsurface materials and the reported depth to groundwater, it is unlikely that liquefaction would occur at the VGS.

3.3.4.3 Landslides

Landslides involve the downslope movement of masses of soil and rock material under gravity. Landslides can be caused by ground shaking, such as earthquakes, or heavy precipitation events. Generally, landslides occur on the sideslopes of mountains comprised of sedimentary materials. Sedimentary rocks are particularly susceptible to landslides because they often contain relatively less competent beds of clays and other fine-grained rocks interbedded with more competent beds of sand and gravel.

Based on the Van Nuys Seismic Hazard Zone Map published by California Division of Mines and Geology the side slopes of the gravel pit may be susceptible to seismic induced landslides (Magula and Owen, 2000). Recommendations in Magula and Owen, 2000, include that the outside edge of foundations should be set back a minimum of 200 feet from the top of the quarry slopes.

3.3.4.4 Potential Soil Contamination

A subsurface investigation was conducted at the VGS in October 2000 (Tetra Tech, Inc., 2000). The investigation included drilling 17 soil borings in the proposed project construction area and collecting 47 samples. All samples were analyzed for total recoverable petroleum hydrocarbons (TRPH) using EPA Method 418.1. The TRPH concentrations were either non-detected or less than 100 mg/kg. The one-foot and five-foot samples were analyzed for Title 22 metals using EPA Test Method series 6010/7000. Concentrations of Title 22 metals were below the regulatory thresholds. The one-foot samples from each boring were also analyzed for soil pH value using EPA Test Method 9145. The soil pH ranged from 6.79 to 8.76. In addition, the one-foot samples

from selected borings were analyzed for the presence of polychlorinated biphenyls (PCBs) (EPA Method 8082), organo-phosphorus (EPA Method 8141A)/organo-chlorine (EPA Method 8081A), and pesticides/herbicides (EPA Method 8151A). Pesticides, herbicides, and PCBs were not detected in the samples.

3.4 Hazards and Hazardous Materials

In general, hazard impacts are not a discipline with specific environmental characteristics that can be easily described or quantified. Instead, hazardous incidents consist of random, unexpected accidental occurrences that may create adverse effects on human health or the environment.

This section describes features of the existing environment as they relate to the risk of a major accident occurring in conjunction with the proposed project. In particular, operation-related activities, at the VGS project site. When evaluating an upset event, a hazards analysis typically includes the following factors:

- The types of materials potentially involved in an upset event;
- The location of sensitive receptors, e.g., residences, schools, and businesses;

- Types of upset events – explosions, fires, accidental release during transport, earthquakes, etc.; and
- The probability of an event occurring.¹

Based on a review of the existing LADWP operations and processes, the greatest potential for an upset condition that could affect the public would result from the release of aqueous ammonia. Ammonia is currently stored at VGS in a 20,000-gallon AST. LADWP adheres, and will continue to adhere to the following safety design and process standards in the operation of the equipment at the site:

- The California Health and Safety Code Fire Protection specifications;
- The design standards established by American Society of Mechanical Engineers, the American Institute of Chemical Engineers, the American National Standards Institute, and the American Society of Testing and Materials; and
- The applicable Cal-OSHA requirements.

LADWP currently utilizes the emergency response capabilities of the City of Los Angeles Fire Department, who will respond to an emergency at the site. Additionally, onsite personnel are trained in appropriate emergency response procedures to initiate in case of a release.

The City of Los Angeles Fire Department has jurisdiction over the Risk Management Program/California Accidental Release Prevention (CalARP) Program in the City of Los Angeles. LADWP has prepared a RMP for the aqueous ammonia that is currently used at the site. LADWP has also prepared an Emergency Response Manual for its personnel at electrical generating stations, including the VGS project site. This manual describes the emergency response procedures that would be followed in the event several release scenarios and the responsibilities for key response personnel. The scenarios include the release of the following:

- Aqueous ammonia stored at bulk tanks currently located at the VGS;
- Natural gas used throughout the generating station involving both ignited and unignited vapors; and
- Release of hydrocarbon fuels stored at the site.

Chapter 4 analyzes various release scenarios associated with the transport, handling, and storage of the additional aqueous ammonia use and storage at the project site. The ammonia concentration was estimated at various distances from the releases for each scenario. Table 3.4-1 below shows the effects of exposure to ammonia at various concentrations for different exposure times. The U.S. EPA risk management endpoint is 200 ppm. Appendix D presents the hazard modeling technical information.

¹ SCAQMD policy when evaluating upset events does not include taking into consideration the probability of the event occurring when making a determination regarding whether or not hazard impacts are significant. Instead, the SCAQMD only considers consequences, e.g., exposures or injuries, which tends to be a more conservative approach.

Seventeen liquid releases of ammonia in California were reported in the U.S. EPA Accidental Release Information database from 1988 to 1998. More than half of those releases were anhydrous ammonia, primarily involving refrigeration units. Nationally, from 1986 to 1998, there were 872 reported releases of ammonia gas, liquid and vapor. Of those, 137 involved liquid ammonia and most of those were anhydrous, not aqueous ammonia.

**Table 3.4-1
Emergency Response Planning Guidelines
(Ammonia Impact)**

Ammonia Concentrations	Responses to Exposure
25 ppm	No significant changes in pulse, blood pressure, and pulmonary function. ^a
50 ppm	Noted acclimation to odor: no significant physiological changes. ^a
100 ppm	With excursions to 200 ppm; caused no significant changes in vital functions; however, eye tearing and some discomfort were noted. ^a
200 ppm	The maximum airborne concentration below which it is believed that nearly all individuals could be exposed for up to one hour without experiencing or developing irreversible or other serious health effects or symptoms which could impair an individual's ability to take protective action. ^b
1,000 ppm	The maximum airborne concentration below which it is believed that nearly all individuals could be exposed for up to one hour without experiencing or developing life-threatening health effects. ^c
American Industrial Hygiene Association (AIHA) Emergency Response Planning Guidelines (ERPG) a = 18 subjects, 8-hour days, for 6 weeks b = AIHA ERPG – 2 c = AIHA ERPG – 3	

3.5 Hydrology and Water Quality

Water issues in the Los Angeles area are complex and affect quality of water for domestic, commercial, industrial and agricultural use. Elements of both the regional and local hydrologic environment are presented in this section.

3.5.1 Surface Water Quality

Extensive urbanization in the southern California area has resulted in significant alteration and deterioration of the natural hydrologic environment. Presently, surface runoff flows into a network of storm drains that empty into several large rivers and a complex of manmade channels. Due to extensive paving and surfacing of the land throughout the area, groundwater recharge by infiltration has steadily decreased while pumping has increased.

3.5.1.1 Federal Requirements

Surface water quality is protected by a number of laws, regulations and plans, including the Federal Water Pollution Control Act, otherwise known as the Clean Water Act (CWA). The primary objective of the CWA is to restore and maintain the chemical, physical, and biological integrity of the Nation's surface waters. Pollutants regulated under the CWA include "priority" pollutants, including various toxic pollutants; "conventional" pollutants, such as biochemical oxygen demand, total suspended solids, oil and grease, and pH; and "nonconventional" pollutants, including any pollutant not identified as either conventional or priority.

The CWA regulates both direct and indirect discharges. The National Pollutant Discharge Elimination System (NPDES) Program (CWA §502) controls direct discharges into waters of the United States. NPDES permits contain industry-specific, technology-based limits and may also include additional water quality-based limits, and establish pollutant-monitoring requirements.

In 1987, the CWA was amended to include a program to address stormwater discharges. In response, the U.S. EPA promulgated the NPDES stormwater permit application regulations.

The national pretreatment program (CWA §307(b)) controls the indirect discharge of pollutants to Publicly Owned Treatment Works (POTW) by industrial users. The goal of the pretreatment program is to protect municipal wastewater treatment plants from damage that could occur if hazardous, toxic, or other wastes are discharged into a sewer system and to protect the quality of sludge generated by these plants. On November 19, 1982, the U.S. EPA promulgated Effluent Guidelines and Standards for the "Steam Electric Power Generating Point Source Category" (40 CFR Part 423). These regulations prescribe effluent limitation guidelines for once-through cooling water and various in-plant waste streams. Discharges to a POTW are regulated primarily by the POTW itself. Additionally, 40 CFR 423.12(a), provides that effluent limitations either more or less stringent than the U.S. EPA standards may be prescribed if factors relating to the equipment or facilities involved, the process applied, or other such factors are found to be fundamentally different from the factors considered in the establishment of the standards.

3.5.1.2 State Requirements

On June 13, 1994, the Los Angeles Regional Water Control Board (LARWQCB) adopted an updated Water Quality Control Plan for the Los Angeles Region (Basin Plan). The Basin Plan incorporates by reference the State Water Resources Control Board's (State Board) water quality control plans, significant State Board policies that are applicable to the Los Angeles Region, and the antidegradation policy.

Pursuant to §402(p) of the CWA and 40 CFR Parts 122, 123, and 124, the State Board adopted a general NPDES permit to regulate stormwater discharges associated with industrial activity in California. Stormwater discharges from power plants operating in California are subject to requirements under this general permit.

Under the State of California Industrial Activities Stormwater General Permit, the VGS site is authorized to discharge stormwater under the following conditions:

- Eliminate non-stormwater discharges to the stormwater system;
- Prepare and implement a Stormwater Pollution Prevention Plan; and
- Develop and implement a Stormwater Monitoring Plan.

3.5.1.3 VGS Surface Water

The VGS site is situated in the San Fernando Valley, which is located in the Los Angeles River Watershed. Due to major flood events at the beginning of the century by the 1950s most of the Los Angeles River was lined with concrete. The majority of the watershed is considered impaired due to a variety of point and nonpoint sources. The pollutants of concern include pH, ammonia, a number of metals, coliform, trash, scum, algae, oil, various pesticides, and volatile organics.

The designated beneficial uses of the Burbank Western Channel surface waters in the Los Angeles River Planning Area (Basin 4B) are potential non-contact water recreation, periodic warm freshwater habitat, and periodic wildlife habitat (LARWQCB, 1995). The Tujunga Wash Flood Control Channel (Tujunga Wash), which is a major tributary of the Los Angeles River, forms the northwest boundary of the site. The ground surface in the vicinity of the site generally slopes from north to south, away from the Tujunga Wash.

Various types of ground cover material occur across the 150-acre VGS site. Approximately 45 percent of the VGS site is covered with paved asphalt and/or concrete or buildings. The other surfaces of the site consist of approximately 15 percent vegetation and/or dirt, 15 percent maintained rock/gravel, and 25 percent dirt/gravel mixture.

The four primary discharge points for stormwater flow at the VGS are the gravel pit, the cooling tower overflow basin, the station cooling water system, and the municipal storm drain system. The stormwater is collected onsite from the tank farm, cooling tower area, power generation area, gravel pit area, and truck unloading area/storage house.

The gravel pit receives approximately 40 percent of the stormwater flow, including stormwater from the tank farm and current power generation area. Most of the stormwater drainage from the area around the cooling towers passes through a skim pond and is retained onsite in an earthen overflow basin, where the water either evaporates or percolates into the ground. Generally, the remaining stormwater runoff from the site collects in drainage ditches along the southeast and southwest property boundaries and is accumulated in two offsite stormwater catch basins prior to discharge to the municipal storm drain system. The municipal storm drain system directs the flow to either to the Sheldon Street Catchbasin or to the San Fernando Road Catchbasin. According to the Los Angeles City Engineering Bureau (Valley Division), these catchbasins discharge to the Burbank Western Flood Control Channel, which connects to the Los Angeles River.

The VGS has a Spill Prevention Control and Countermeasure (SPCC) Plan in place, as required by federal regulations. The SPCC Plan, along with the Integrated Emergency Response Plan, outlines emergency procedures, operating procedures, and engineering controls (e.g. secondary containment) necessary to prevent spills, overflows, or other incidents that may discharge hazardous materials to surface water.

The process water and industrial wastewater system is diagramed in Figure 3.5-1. Municipal water, which is obtained from the City of Los Angeles, LADWP and used at the VGS site, is directed to the following four primary systems:

- Sanitary water system
- Bearing cooling water system
- Station cooling water system
- Boiler system

Water in the sanitary water system ultimately is discharged to the municipal sewer system. Water from the bearing cooling water system either evaporates or is recycled in the station cooling water system. The station cooling water system recirculates the water to the cooling tower operations. However, approximately nine gallons of water per minute per turbine is replaced and the blowdown is discharged. Water directed to the boiler system undergoes physical and chemical treatment prior to use in the boilers. Chemicals such as phosphates, chlorine, acids, and caustics are used in the treatment process. Boiler blowdown water, as well as water from the power generation unit floor drains, oil/water separator, sump overflow, and demineralizer storage tank overflow, is diverted to wastewater basins. The water from the basins is discharged to a holding tank prior to being introduced into the cooling water system for recirculation.

The VGS is authorized to discharge industrial wastewater to the City of Los Angeles sewer system under Industrial Wastewater Permit No. W-173173, which expires February 28, 2003. Discharge limitations and sampling frequencies for the VGS site are identified in Table 3.5-1.

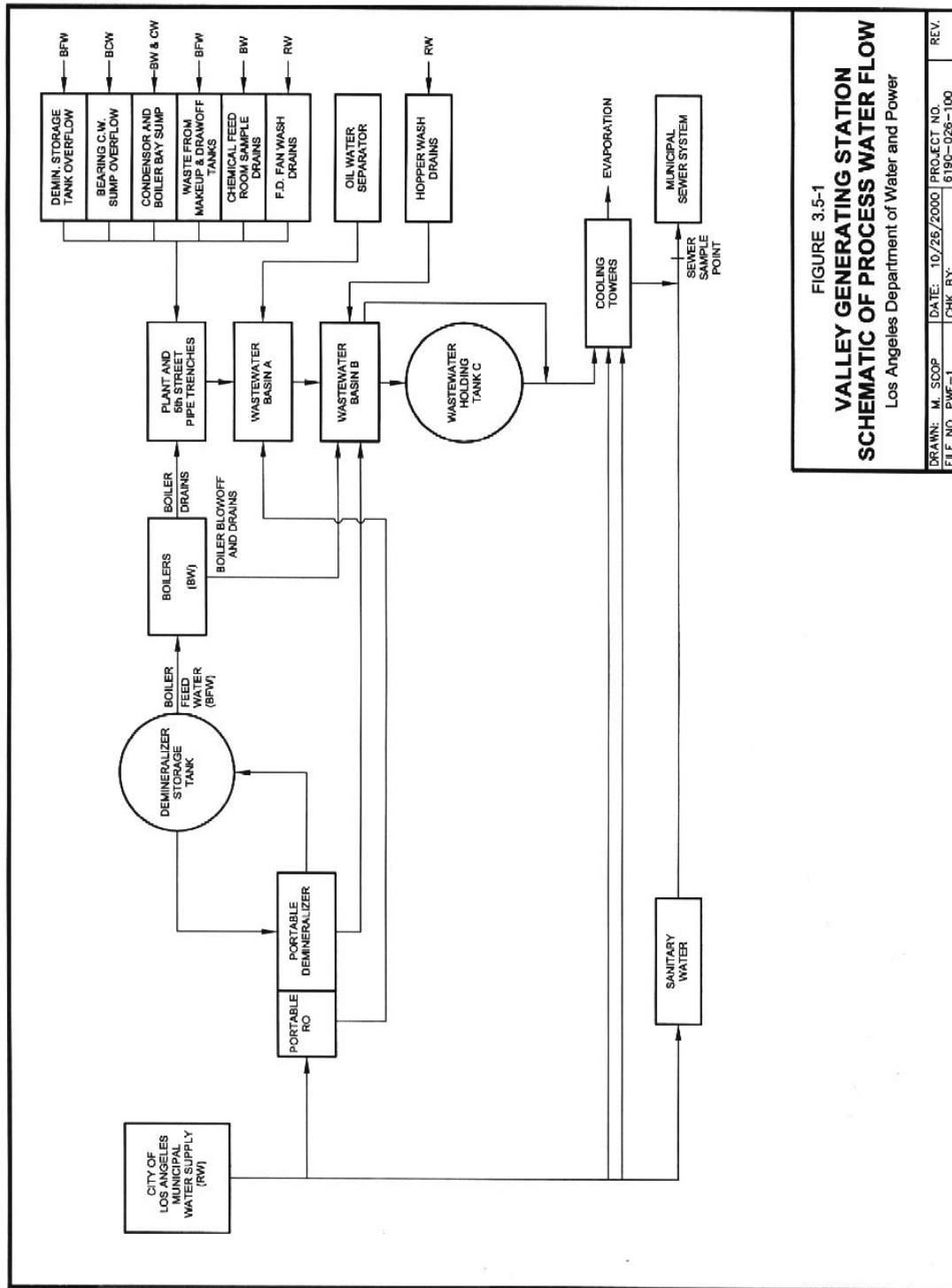

Figure 3.5-1 Valley Generating Station Schematic of Process Water Flow

**Table 3.5-1
Valley Generating Station's Discharge Limitations**

Sample Point 01: Discharge Limitations		
Constituent	Local Instantaneous Maximum, mg/l	Federal
		Instantaneous Maximum, mg/l
Arsenic	3.00	---
Cadmium	15.00	---
Chromium, total	10.00	0.20
Copper	15.00	---
Lead	5.00	---
Nickel	12.00	---
Silver	5.00	---
Zinc	25.00	1.00
Cyanide, total	10.00	---
Cyanide, free ^a	2.00	---
Remaining 124 priority pollutants	---	No detectable amount
Polychlorinated biphenyl compounds	---	No discharge allowed
Sulfides (dissolved)	0.10	---
Oil and grease (dispersed)	600.00	---
Oil and grease (floatable)	None visible	---
pH (standard units)	5.50 – 11.00	---
Sample Point 02: Discharge Limitations		
Constituent	Federal	
	Daily Maximum, mg/l	
Copper	1.00	
Flow	---	Report
Arsenic	Once / 6 mo.	Grab or composite
Cadmium	Once / 6 mo.	Grab or composite
Chromium, total	Once / 1 mo.	Grab
Copper	Once / 6 mo.	Grab or composite
Lead	Once / 6 mo.	Grab or composite
Nickel	Once / 6 mo.	Grab or composite
Silver	Once / 6 mo.	Grab or composite
Zinc	Once / 1 mo.	Grab

**Table 3.5-1 (Concluded)
Valley Generating Station’s Discharge Limitations**

Sample Point 02: Discharge Limitations (continued)		
Constituent	Federal	
	Daily Maximum, mg/l	
Cyanide, total	Once / 6 mo.	Grab
Cyanide, free	Once / 6 mo.	Grab
Sulfides, dissolved	Once / 6 mo.	Grab
Chlorides	Once / 6 mo.	Grab or composite
Oil and grease	Once / 6 mo.	Grab
pH ^b	Once / 6 mo.	Grab
Copper	once/ Batch ⁵	Composite

a = Cyanide (free) shall mean cyanide amenable to chlorination as defined by 40 CFR 136.
 b = The pH of the wastewater discharge to the sewer system shall be monitored and recorded continuously using a pH meter and recorder. A logbook for calibration of the pH meter shall be maintained. The pH charts shall be initiated daily by an operator at the facility.

3.5.2 Groundwater Quality

The VGS is located in the San Fernando Valley Groundwater Basin (SFVGB). The groundwater quality in this area has been impacted by volatile organic compounds from industry, nitrates from subsurface sewage disposal, and past agricultural activities. Because the SFVGB does not have continuous effective confining layers above groundwater, pollutants have seeped through the upper sediments into the groundwater. The LARWQCB is investigating area-wide sources of groundwater contamination. The SFVGB has been subdivided into four discrete Superfund sites for clean up and management. The VGS is located in Area 1, which is also referred to as the North Hollywood Operable Unit. Interim cleanup measures have been implemented in Area 1, and include groundwater pumping and treatment. The VGS has not been identified as a source for the groundwater contamination. Depth to groundwater in the project site is expected to occur between 180 and 200 feet bgs (Magula and Owen, 2000).

3.6 Noise

Noise is usually defined as sound that is undesirable because it interferes with speech communication and hearing, is intense enough to damage hearing, or is otherwise annoying (unwanted sound). Since environmental noise, by its nature, varies with time, it is beneficial to define certain measurement terms that are used to characterize this fluctuating quantity as well as some other basic acoustical terminology.

Sound levels are measured on a logarithmic scale in decibels (dB). The universal measure for environmental sound is the “A” weighted sound level (dBA), which is the sound pressure level in

decibels as measured on a sound level meter using the A-weighted filter network. “A” scale weighting is a set of mathematical factors applied by the measuring instrument to shape the frequency content of the sound in a manner similar to the way the human ear responds to sounds.

The residual environmental noise level is the quasi-static noise level that exists in the absence of all identifiable, sporadic noise events such as automobile pass-byes, aircraft fly-overs, intermittent dog barking, etc. In most environments, this level is composed of the cumulative sum of far-off, indistinguishable road transportation sources. The residual level itself varies slowly with time as these sources increase or diminish. It has been found that the measurable sound level quantity, L90 (in dBA) well represents the residual sound level. L90 is the level that is exceeded 90 percent of the sample time.

The true energy average level over a specific time period is defined as the equivalent level (Leq). Leq is the level corresponding to a steady noise level over a given sample period with the same amount of acoustic energy as the actual varying noise level. Hence, Leq provides a measure of the true average sound level in an area and includes all sporadic or transient events. Leq is usually measured in hourly intervals over long periods in order to develop 24-hour noise levels.

One 24-hour measure of interest for this project is the Community Noise Equivalent Level (CNEL). This noise descriptor is the equivalent noise level over a 24-hour period mathematically weighted during the evening and night when residents are more sensitive to intrusive noise. The daytime period is from 7:00 am to 7:00 pm; evening from 7:00 pm to 9:00 pm; and nighttime from 9:00 pm to 7:00 am. A weighting factor of five dB is added to the measured evening levels and 10 dB to the nighttime levels. The weighted levels over a 24-hour period are then averaged to produce the single number CNEL rating.

In addition to the absolute noise level that might occur when a new noise source is introduced into an area, it is also important to consider the level of the existing noise environment. If the existing noise environment is quite low and a new noise source greatly increases the noise exposure (even though a criterion level might not be exceeded), some impact may occur. General rules of thumb for real-life noise environments are that a change of over five dB is readily noticeable and would be considered a significant increase. Changes from three to five dB may be noticed by some individuals and would be considered a substantial increase, possibly resulting in sporadic complaints; and changes of less than three dB are normally not noticeable and are considered “insignificant.”

3.6.1 Regulations

The project consists of modifications at the VGS facility, which is located within the City of Los Angeles in the community of Sun Valley.

Federal, state, and local agencies regulate environmental and occupational, as well as, other aspects of noise. Federal and state agencies generally set noise standards for mobile sources such as aircraft and motor vehicles, while regulation of stationary sources is left to local agencies.

Local regulation of noise involves implementation of General Plan policies and Noise Ordinance standards. Local General Plans identify general principles intended to guide and influence development plans, and Noise Ordinances set forth specific standards and procedures for addressing particular noise sources and activities. The VGS facility is governed by local ordinances.

Noise generated from the operation and construction of the modifications of the VGS are subject to the City of Los Angeles noise regulations summarized in Table 3.6-1. Based on the City of Los Angeles Noise Element of the General Plan, noise levels to 65 dBA are considered "conditionally acceptable" for residential uses. The Noise Element of the General Plan considers CNEL noise levels of 70 to 75 dBA "conditionally acceptable" for industrial uses.

The City of Los Angeles Municipal Code, Chapter IV, Article 1, §41.40 (Amended Ordinance Number 161,574), prohibits construction or repair of or excavation for buildings or structures which involves the use of power machinery between the hours of 10:00 pm and 7:00 am. Construction projects which constitute an emergency or where undue hardship or unreasonable delay would result from the interruption of construction can be exempted with written permission of the Board of Police Commissioners. These requirements may be in effect for this project. The City of Los Angeles Municipal Code, Chapter XI, Article 2, §112.05, requires that noise levels generated by construction equipment within a residential zone not exceed 75 dBA at a distance of 50 feet from the source between the hours of 10:00 pm and 7:00 am. Noise must be monitored to avoid an increase beyond 75 dBA in any residential zone of the City of Los Angeles or within 500 feet thereof, and will be monitored to avoid any increase beyond 75 dBA at distance of 50 feet from the source of the noise.

**Table 3.6-1
City of Los Angeles Noise Ordinances**

Ordinance	Construction Limit (dBA)	Operations Limit (exterior dBA except where noted)
Noise Element of the General Plan of the City of Los Angeles	65 dBA CNEL or less –Considered "conditionally acceptable" for residential use 70-75 dBA CNEL – considered "conditionally acceptable for industrial use	65 dBA CNEL or less –Considered "conditionally acceptable" for residential use 70-75 dBA CNEL – considered "conditionally acceptable for industrial use
City of Los Angeles Municipal Code Chapter XI, Article 2, §112.05	Requires that noise levels generated by construction equipment within a residential zone not exceed 75 dBA	Not applicable
City of Los Angeles Municipal Code Chapter IV, Article 1, §41.40	Construction activities prohibited without a special permit between the hours of 10:00 pm and 7:00 am	Not applicable

3.6.2 Existing Noise Environment

The VGS occupies a parcel of land bounded by Glenoaks Boulevard to the northeast; Sheldon Street to the southeast; San Fernando Road to the southwest; and a flood control channel to the northwest, beyond which is Branford Road. The area surrounding the facility is primarily commercial/industrial; however, an emergency medical clinic, a hospital and two motels are present adjacent to the site on San Fernando Road. A sand and gravel plant is located on the northwest portion of the site. There are no residences located in the immediate vicinity of the VGS. The nearest residential properties are located approximately one-half mile to the north. Therefore, there are limited noise receptors in the vicinity of the proposed project.

3.7 Transportation/Traffic

The transportation system utilized in the SCAQMD's jurisdiction is a multi-faceted and multi-modal system for moving people and goods. It includes an extensive network of freeways, highways and roads; public transit; and air and sea routes. This section describes the project site in relation to the regional and local transportation setting. The existing circulation system is discussed, and existing traffic volumes and levels of service are summarized.

3.7.1 Surrounding Highway and Rail Network

Regional transportation facilities in the vicinity of the proposed project site provide accessibility to the entire southern California region. The VGS site is located northwest of the Golden State Freeway (Interstate 5) and Hollywood Freeway (State Route 170) interchange.

In addition to the vehicular system, the project site is serviced by a network of railroad facilities. This system provides an alternative mode of transportation for the distribution of goods and materials. The railroad network includes an extensive system of private railroads and several publicly owned freight lines. The Southern California Regional Rail Authority operates commuter rail systems in the Los Angeles area. Additionally, Amtrak provides inter-city service, principally between San Diego and San Luis Obispo.

3.7.2 Local Roadways and Circulation Routes

A traffic analysis was performed for the project by Austin-Foust Associates. The analysis is included in Appendix E. The morning peak hour of the adjacent street system occurs during the period of 7:00 am to 9:00 am and the afternoon peak hour occurs during the period of 4:00 pm to 6:00 pm as indicated in the Congestion Management Program (CMP) Guidelines. Based on the traffic analysis, the 19 major intersections in the vicinity of the VGS are presently operating at an acceptable level of service during the morning and afternoon peak hour under existing conditions with the exception of four our locations (SR-170 NB on/off ramp and Osborne Street, Interstate 5 SB on/off ramp and Osborne Street during the PM peak hour, and Coldwater Canyon/Sheldon Street and Roscoe Boulevard during both the AM and PM peak hours).

The proposed project may affect seven primary roadways in the vicinity of the VGS, which are described below.

Golden State Freeway (Interstate 5) – An eight-to-ten lane freeway traveling south-north from Santa Ana to Sacramento. It passes west of the project site and provides interchanges at Sheldon Street, Tuxford Street, Osborne Street, and Sunland Boulevard.

Sheldon Street/Coldwater Canyon – A four-lane roadway providing direct access to the project site and extends west and south from the project site. There are a few signalized cross streets, consisting of Laurel Canyon, San Fernando Road, and Glenoaks Boulevard. All other cross street traffic is controlled by STOP signs. Sheldon Street traffic does not stop at these locations. Sheldon Street is bounded by primarily commercial/industrial uses.

Osborne Street, Tuxford Street, Sunland Boulevard – East-west arterial roadways located west of the project site that provide access to San Fernando Road and Glenoaks Boulevard. Additionally, these roadways provide access to ramp connections with Interstate 5.

San Fernando Road, Glenoaks Boulevard - North-south roadways that intersect with Osborne Street, Tuxford Street, and Sunland Boulevard, thereby providing access to the VGS via Sheldon Street.

Roscoe Boulevard – Roscoe Boulevard changes into Tuxford Street as it turns northeast from an east-west direction. Its ramp connections with SR-170 provide access to the local street system via Coldwater Canyon/Sheldon Street and Roscoe Boulevard/Tuxford Street.

Existing volumes of traffic are presented below in Table 3.7-1.

**Table 3.7-1
Intersection Capacity Utilization (ICU) Summary – Existing Conditions**

Intersection	AM	PM
1. Glenoaks & Sheldon	0.617	0.463
2. Glenoaks & Tuxford	0.670	0.646
3. Sunland & Glenoaks	0.834	0.697
4. San Fernando & Osborne	0.748	0.799
5. San Fernando & Sheldon	0.629	0.800
6. Arleta & Sheldon	0.490	0.754
7. Coldwater Canyon & Roscoe	0.999	1.106
8. SR-170 SB Ramp & Roscoe	0.655	1.206
9. SR-170 NB Ramp & Roscoe	0.842	0.888
10. SR-170 NB off & Sheldon	0.519	0.509
11. SR-170 SB ramp & Arleta	0.603	0.749
12. Sunland & Interstate 5 NB on/off	0.763	0.594
13. Sunland & Interstate 5 SB on/off	0.769	0.848
14. Interstate 5 NB on/Rincon & Sheldon	0.637	0.575
15. Laurel Canyon & Interstate 5 SB on/off	0.520	0.656
16. Laurel Canyon & Interstate 5 NB off	0.449	0.500
17. Interstate 5 NB on/off & Osborne	0.607	0.704
18. Interstate 5 SB on/off & Osborne	0.878	0.932
19. Laurel Canyon & Sheldon	0.740	0.765
Level of Service Ranges:	.00 – .60	A
	.61 - .70	B
	.71 - .80	C
	.81 - .90	D
	.91 – 1.00	E
	Above 1.00	F

3.8 Other Issue Areas Eliminated During the Initial Study

The NOP/IS for the proposed project, which was released to the public on May 4, 2001 included an environmental checklist of approximately 17 environmental topics. The NOP/IS concluded that the project would have no significant direct or indirect adverse effects on the following environmental topics:

- Aesthetics
- Agricultural Resources
- Mineral Resources
- Population/Housing

Chapter 3 – Existing Setting

- Biological Resources
- Cultural Resources
- Energy
- Land Use/Planning
- Public Services
- Recreation
- Solid and Hazardous Waste
- Water Supply